

TRACTOR MOUNTED ROTAVATOR

- A Success Story -



All India Coordinated Research Project on

Farm Implements and Machinery

Central Institute of Agricultural Engineering

Nabi Bagh, Berasia Road, Bhopal - 462 038, India

TRACTOR MOUNTED ROTAVATOR

Year	:	2002
Published by	:	Coordinating Cell AICRP ON FARM IMPLEMENTS AND MACHINERY CENTRAL INSTITUTE OF AGRICULTURAL ENGINEERING Nabi Bagh, Berasia Road Bhopal-462 038, India
Design and development:		Commercially available
Compilation	:	NN Narkhede AA Deogirikar <i>Dr PDKV, Akola</i>
Editing	:	MM Pandey PC, AICRP on FIM <i>CIAE, Bhopal</i>
Art, Cartography & Proof Reading	:	SS Mandvikar Yashwant Bhokardankar <i>CIAE, Bhopal</i>
Word Processing	:	Zackaria V John <i>CIAE, Bhopal</i>
Reprography	:	Radheyshyam Kushwaha <i>CIAE, Bhopal</i>

TRACTOR MOUNTED ROTAVATOR

Introduction

The effective mechanization contributes to increase in production in two major ways, firstly the timeliness of operation and secondly a good quality of work. The requirement of power for certain operations like seed bed preparation, cultivation and harvesting becomes so great that the existing human and animal power is becoming inadequate.

Tillage is the most important unit operation in agriculture. It is done mainly to loosen the upper layer of soil, to mix the soil with fertilizer and to remove weeds. As a result of this processing the water-air, thermal and nutrient regimes of the soil are improved in the interest of the growth and development of crops.

The most widespread method of tilling land is ploughing with moldboard ploughs. In the process of ploughing, the soil layer is subjected to various deformations and is turned to the bottom of the groove. However, by the use of moldboard ploughs the upper layer of the soil is not always loosened to the desired extent, nor is the proper mixing of the different layers achieved. Hence, additional operations such as discing, cultivation and harrowing, etc., are carried out to improve on the ploughing.

Traditional Practices and Need for Development

Traditionally draught animals (oxen and bull buffaloes) have been used in India for seedbed preparation. With increased cropping intensity, farmers have supplemented animate power with tractors, power tillers. Farm power ensures timeliness operations, besides reducing drudgery. Available farm power and energy use per hectare are the indicators of modernization of agriculture. In developing countries like India, few farm operations have been partially mechanized and rest of the operations are done by the draught animals. The land preparation aspect of crop is energy intensive operation due to the presence of heavy soils and tendency to develop cracks. At present, because of lack of knowledge, experience and facility, farmers are stuck to the tractor operated / bullock operated MB ploughs and blade harrows for land preparation.

Evolution / Design Process

The rotary tillers has been a device that inspired both enthusiasm and controversy since its original development. The first machine was introduced into the United States by a Swiss Manufacturer in 1930s. Shortly after this, several American companies started manufacturing rotary tillers, the greatest growth was after World War II.

Salient Features of the Rotary Machine (Rotavator)

Preparation of seed bed for wheat after harvesting of rice crop is very difficult in heavy soils. Due to development of deep cracks in the soil, considerable difficulty is experienced with mould board plough, disc plough and cultivators. Clod formation in these types of soils necessitates many operations of conventional implements to be carried out. In addition, the rice stubbles after combine harvesting remain intact and create problems in subsequent sowing operation.

The tractor mounted rotavator holds promise for overcoming these problems. There are five discs in rotavator on each of which tines are mounted. A leveller is provided on the rear of the machine. The rotavator is mounted on three point linkage system of tractor of 26 kW or above and the power to the tilling unit is provided through tractor pto. The rotating blades of the rotavator give impact on soil surface and throw soil upward because of its rotational speed and pulverises soil by breaking clods.

The principal parts of the rotavator are (1) Cardon shaft, (2) adjustable curved flats (skid), (3) rotary / rotating blades, (4) top yoke, (5) gear box assembly, (6) spur gear assembly, (7) rotar assembly, (8) metal shield, (9) rack (for skid adjustment), (10) trailing board. Fig. 1 shows the schematic diagram of the tractor mounted rotavator.

The gap between rotating tines and shield is adjustable, which controls the degree of pulverization. Lowering this gap, increases pulverization. This cover also helps to distribute the pulverized soil equally on ground surface to get leveled land. Adjustable curved plates on both the sides can be used to change the working depth according to the need and situation. Different types of blades are used on the rotavator. Rotavators are available in different sizes of 0.83 - 1.455 m width. The size of the rotavator is expressed in width of cut (Table 1).

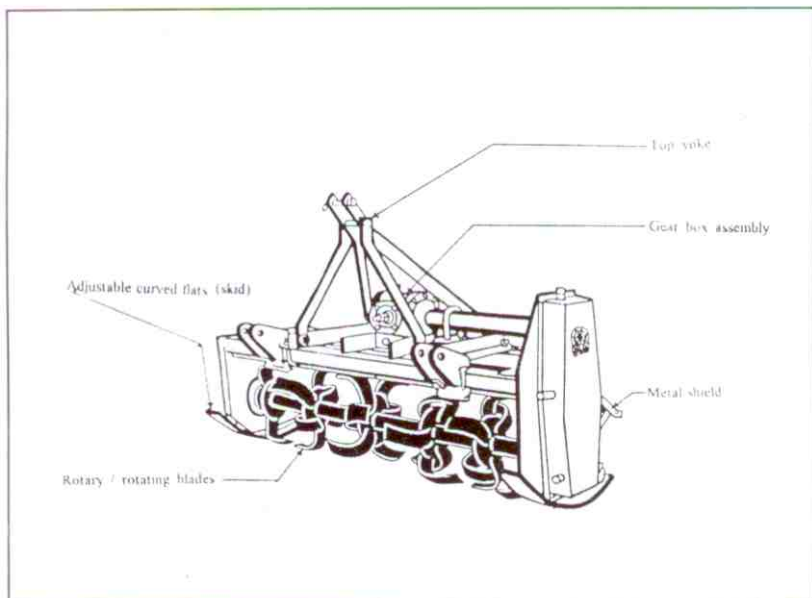

Fig 1 Schematic of the tractor mounted rotavator

Table 1 Selection of the Rotavators according to tractor hp

Sl. No.	Tractor, hp	Working width, mm	Working depth for blade, mm	Weight, kg
1	25 to 35	836	152	230
2	35 to 40	1042	152	260
3	40 to 47	1248	152	280
4	50 to 60	1455	152	310

Performance of the Machine

The rotavator was field tested in heavy and light soils at Dr PDKV, Akola, Centre of AICRP on FIM. The field performance tractor mounted rotavator is given in Table 2.

Table 2 Performance results of tractor mounted rotavator at Dr PDKV, Akola centre

Sl. No.	Parameters	Heavy soil	Light soil
1	Gear selected for tractor (47 hp)	Low 2 nd	Low 2 nd
2	Forward speed of travel, kmph	3.86	3.97
3	Rated working width of rotavator, m	1.42	1.42
4	Actual working width, m	1.3	1.34
5	Working depth, cm	6 to 10	8 to 11
6	Field capacity, ha/h	0.34	0.37
7	Field efficiency, %	62.44	65.66
8	Fuel consumption, l/ha	9.05	8.9
9	Pulverization, %	82.54	91.15
10	Cost of tillage, Rs/ha	725	670
11	Saving obtained over the existing method of tractor mounted blade harrow:		
	(a) Time, %	53.5	37.5
	(b) Cost, %	28.13	10.6

The trials were witnessed by 300 farmers. The farmers were shown the suitability of the equipment and superiority of tillage obtained and saving of cost and time over the traditional method.

At JNKVV, Jabalpur Centre of AICRP on FIM, 41.3 ha area was covered in 16 farmers fields in 7 villages for seedbed preparation for wheat and rice crop (Fig 2). The performance results are given in Table 3.



Fig 2 Field testing of Tractor Mounted rotavator for puddling of paddy fields at JNKVV, Jabalpur

Table 3 Performance results of tractor mounted rotavator at JNKVV, Jabalpur centre

Parameters	Seedbed preparation			Puddling	
	Rotavator	Cultivator	Disc harrow	Rotavator	Puddler
Field capacity, ha/h	0.43	0.62	1	0.38	0.63
Field efficiency, %	79	72	70	70	70
Fuel consumption, l/h	3.2	3.3	3.0	3.5	3.5
Clod size after operation, mm (MWD)	43	105	75	-	-
Speed of operation, km/h	3.6	3.1	5.5	4.5	4.5
Savings	56% fuel saving over cultivator			21% fuel & time saving over puddler	
	23% fuel saving over disc harrow				
	51% time saving over cultivator				
	19% time saving over disc harrow				

From the feasibility trials it has been found that the use of rotavator reduced the number of operations thereby increasing the overall field capacity and reducing the time required for seedbed preparation. The seedbed quality obtained was superior to that with conventional practices and it was also possible to incorporate rice stubbles into soil. The rotavator is recommended for large scale popularization.

Status of Technology

Tractor mounted rotavator has also been identified to be an equipment for preparation of seedbed in fewer passes. This is not only a time saving device, but it also helps in incorporating rice stubbles into the soil.

JNKVV, Jabalpur; PDKV, Akola; ANGRAU, Hyderabad; GBPUAT, Pantnagar; HAU, Hisar; KAU, Tavanur and MPKV, Pune centres carried out feasibility testing of tractor mounted rotavator covering about 250 ha area (Fig 3).



Fig 3 Field testing of Tractor mounted rotavator for seedbed preparation (dryland)

The rotavator is gaining popularity amongst the farmers due to following benefits over traditional method of land preparation.

- (a) After harvesting the previous crop, soil can be prepared in short period for the next crop and the soil moisture content can be used effectively.
- (b) Soil pulverization with rotavator is better than traditional implements.
- (c) Cost of operation is less as energy, time and fuel requirement is less.
- (d) It destroys weeds, stubbles of paddy, sugarcane, maize, cotton completely and cuts previous crop residue into fragments and buries it into soil, which in turn increases the soil fertility.
- (e) It can be used effectively for inter-cultural operation in horticultural crops and for puddling in paddy cultivation.
- (f) As the direction of rotation of rotavator blades and the wheel of tractor is same, the rotational energy of the blades help tractor to push ahead which in turn reduces tyre friction.
- (g) With rotavator 1.5 to 2.0 hectare of land can be prepared in one day (of 8 h).

Specifications of the rototiller

Overall dimensions, mm, LxBxH	:	1650 x 650 x 1000
Type of blades and no.	:	L type, Total 42 nos.
Required pto rpm	:	540
Rotor, rpm	:	210
Safety device	:	Shear bolt
Source of power	:	Tractor, above 45 hp
Price, Rs.	:	65,000/-

Appendix-II

List of few Manufacturers and their volume of production

Sl. No.	Name of manufacturer	Volume of production				
		1995-96	1996-97	1997-98	1998-99	1999-00
1	The Maharashtra Agro Industries Development Corporation Ltd., Rajan House, 3 rd Floor, Prabhadevi, Mumbai-400 025	310	346	282	333	333
2	JNP Agro Systems Pvt. Ltd., 15, Poes Road, 3 rd Street, Teynampet, Chennai-600 018	90	225	300	425	580
3	Popular Agency, 481-E, Shahu Road, Shahupuri, Kolhapur-416 001	-	-	7063	7722	7657
4	The Oriental Science Apparatus Workshops, Jawaharlal Nehru Marg, Ambala Cantt, Haryana-133 001	-	-	-	8	17

mechanization
Substance of a desirable level of agricultural productivity goes hand in hand with mechanization of different farm operations, which aims at achieving timeliness of operations, efficient use of inputs, improvement in quality of produce and safety and comfort of farmers, and reduction in loss of produce and drudgery of farmers.

The All India Coordinated Research Project (AICRP) on Farm Implements and Machinery (FIM) with its 28 centres in different parts of the country, has been endeavouring to develop, test and popularize need based farm implements and machinery for different regions. The research and development activity under AICRP on FIM involves design, development, testing and design refinement of farm implements and machinery. Prototype manufacturing activity is for multiplication of research prototypes for multi-location trials, development of manufacturing technology for new machines and promoting their manufacture by involving local manufacturers. Prototype feasibility testing activity of a Centre includes identification of farm mechanization needs under local agro-climatic conditions and identification and adaptation of machines to fill the identified mechanization gaps through their feasibility trials.

One hundred-fifty-nine farm implements and machinery have been designed and developed under the AICRP on FIM. Twenty-three of these have been commercialized. This publication is one among the series of such publications being brought out by the Project on successful technologies.

